

# SW 21 Combi

## Contents

Stand: 30.03.2017 21:20

SW-21

**cleanfix**  
Best Made Quality

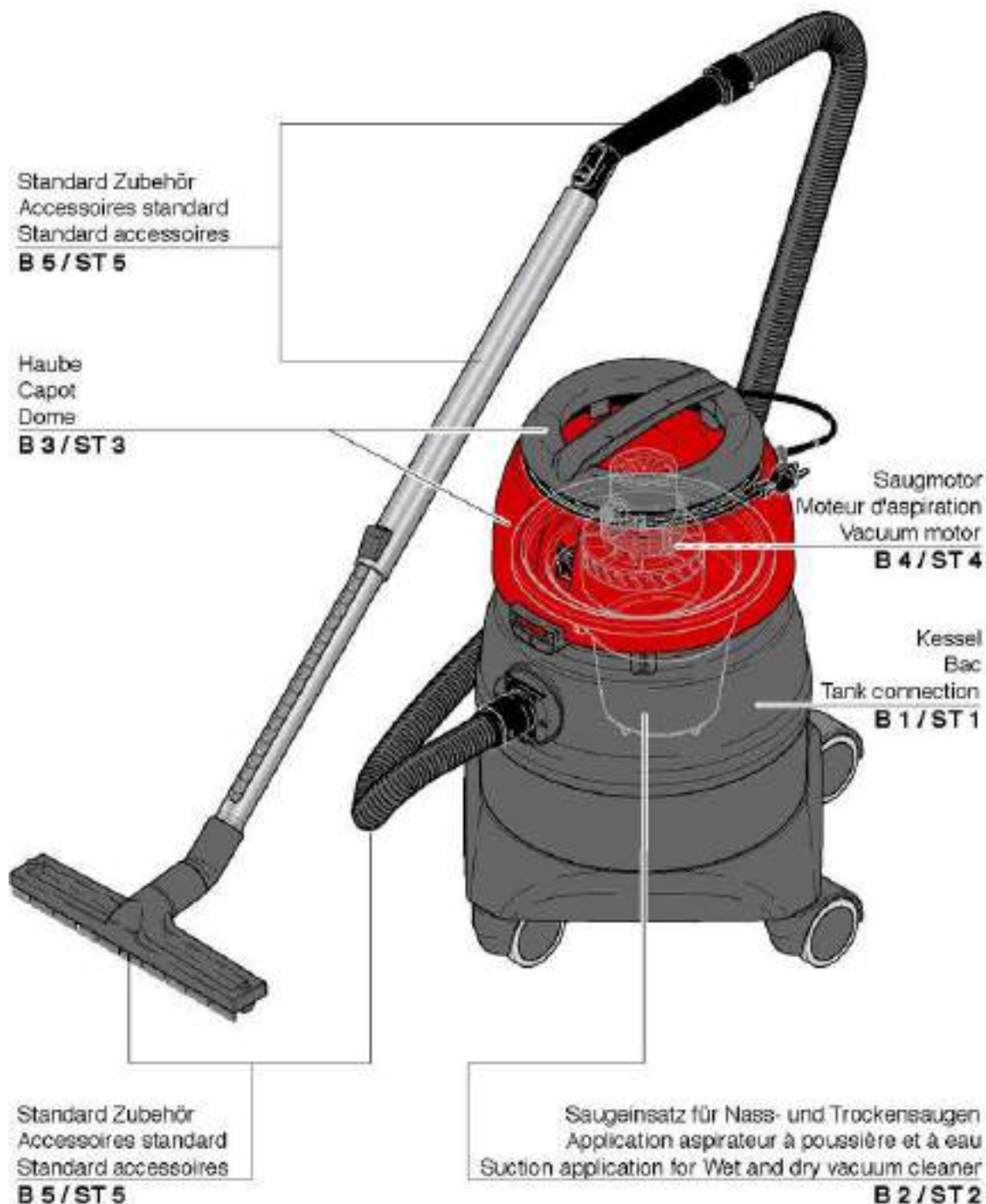

Stromlaufplan  
Diagramme électrique  
Wiring diagram  
**B 6 / ST 6**

# SW 21 Combi

## Dome

Stand: 30.03.2017 21:21

SW-21

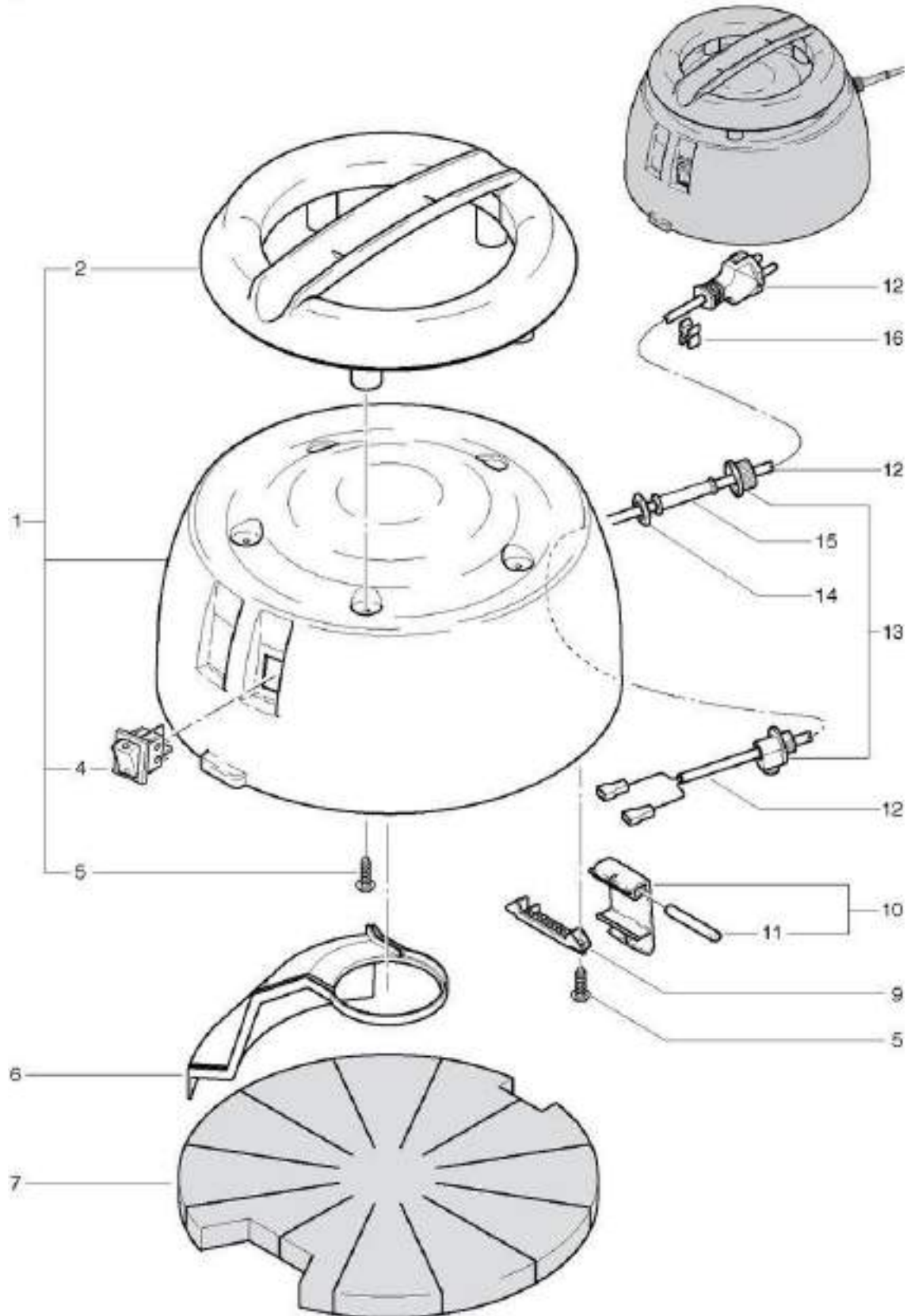

# SW 21 Combi

## Standard accessoires

Stand: 30.03.2017 21:22

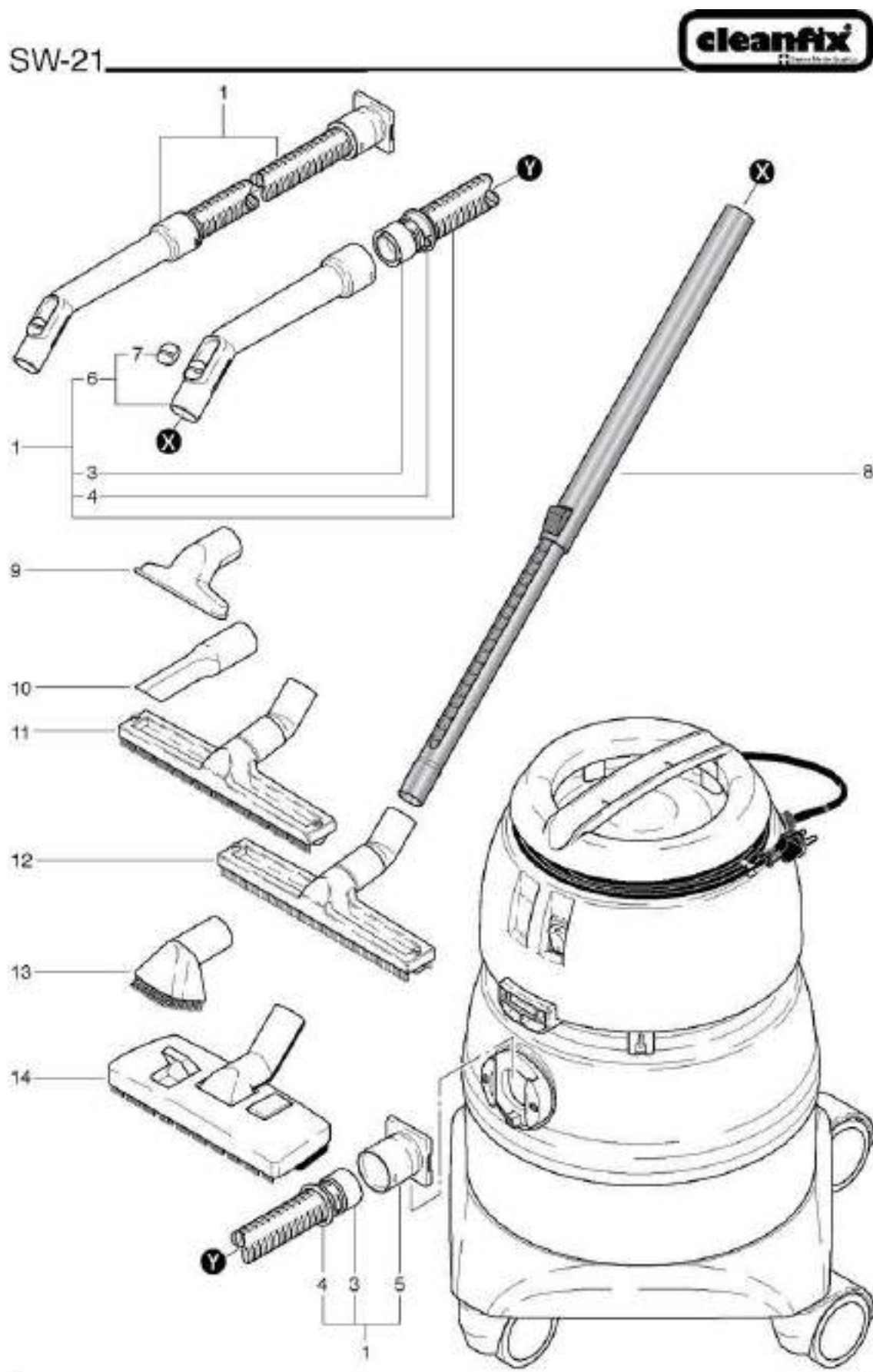

# SW 21 Combi

## Suction application for Wet and dry vacuum cleaner

Stand: 30.03.2017 21:21

SW-21

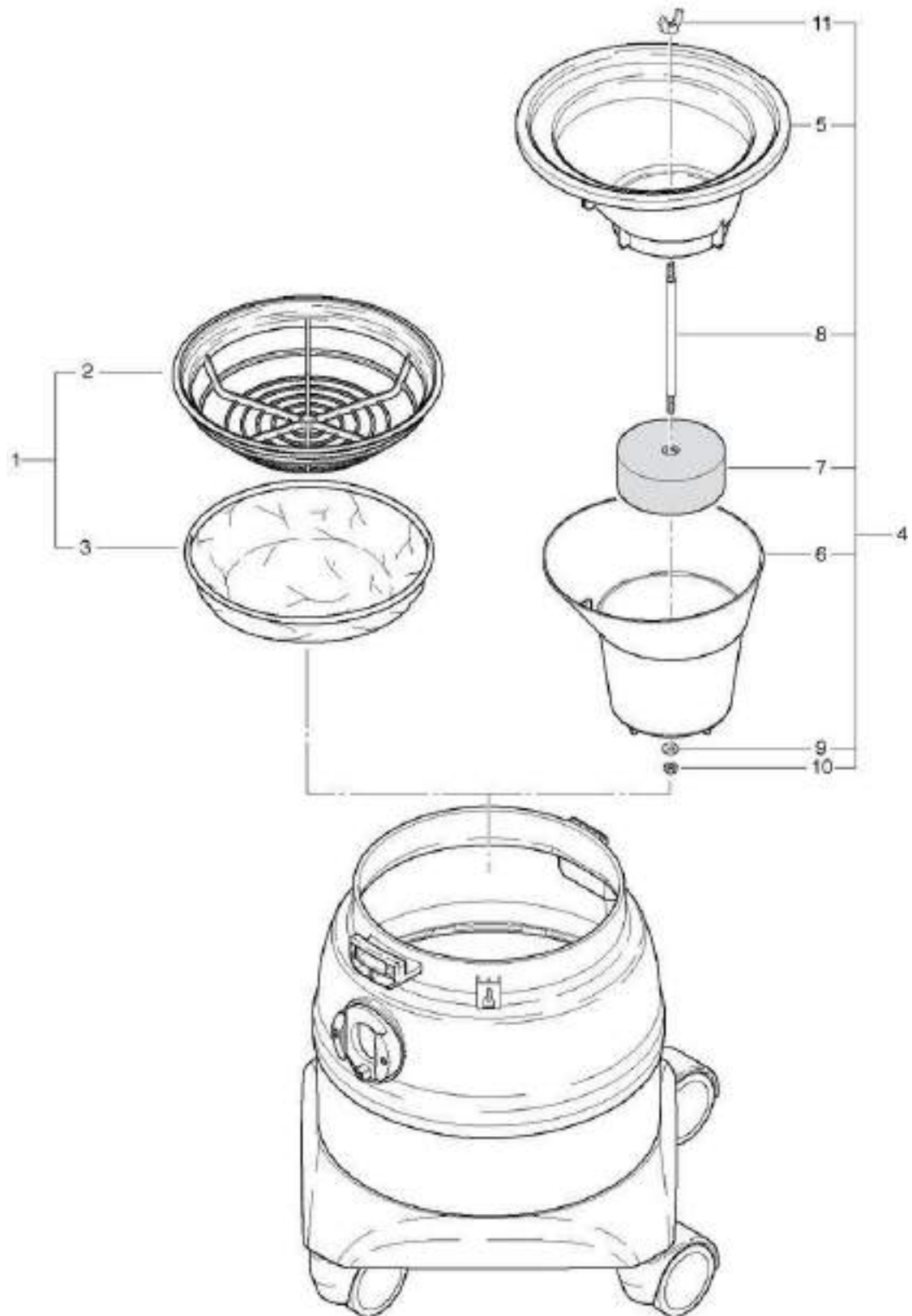

# SW 21 Combi

## Tank connection

Stand: 30.03.2017 21:21

SW-21

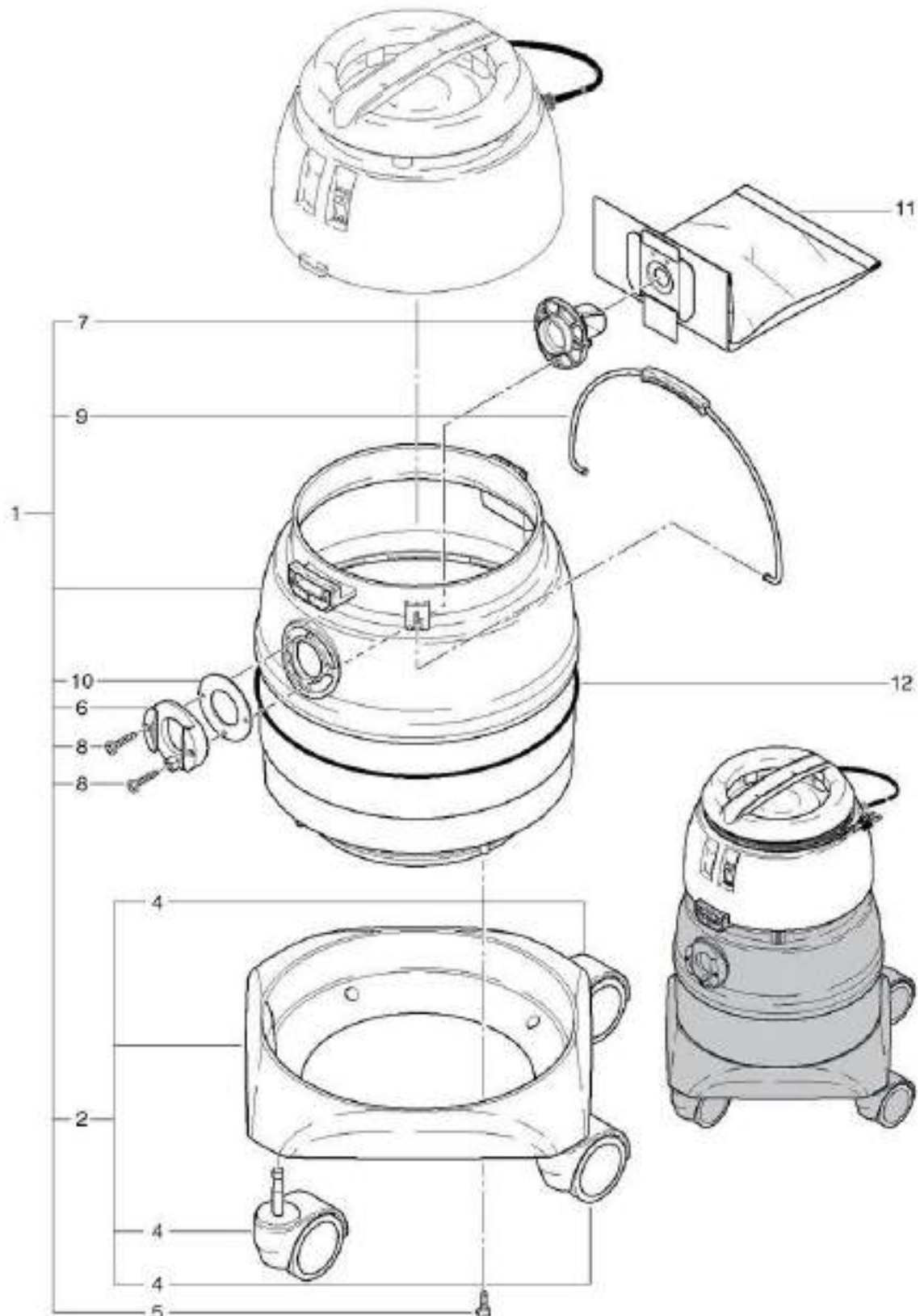

# SW 21 Combi

## Vacuum motor

Stand: 30.03.2017 21:21

SW-21

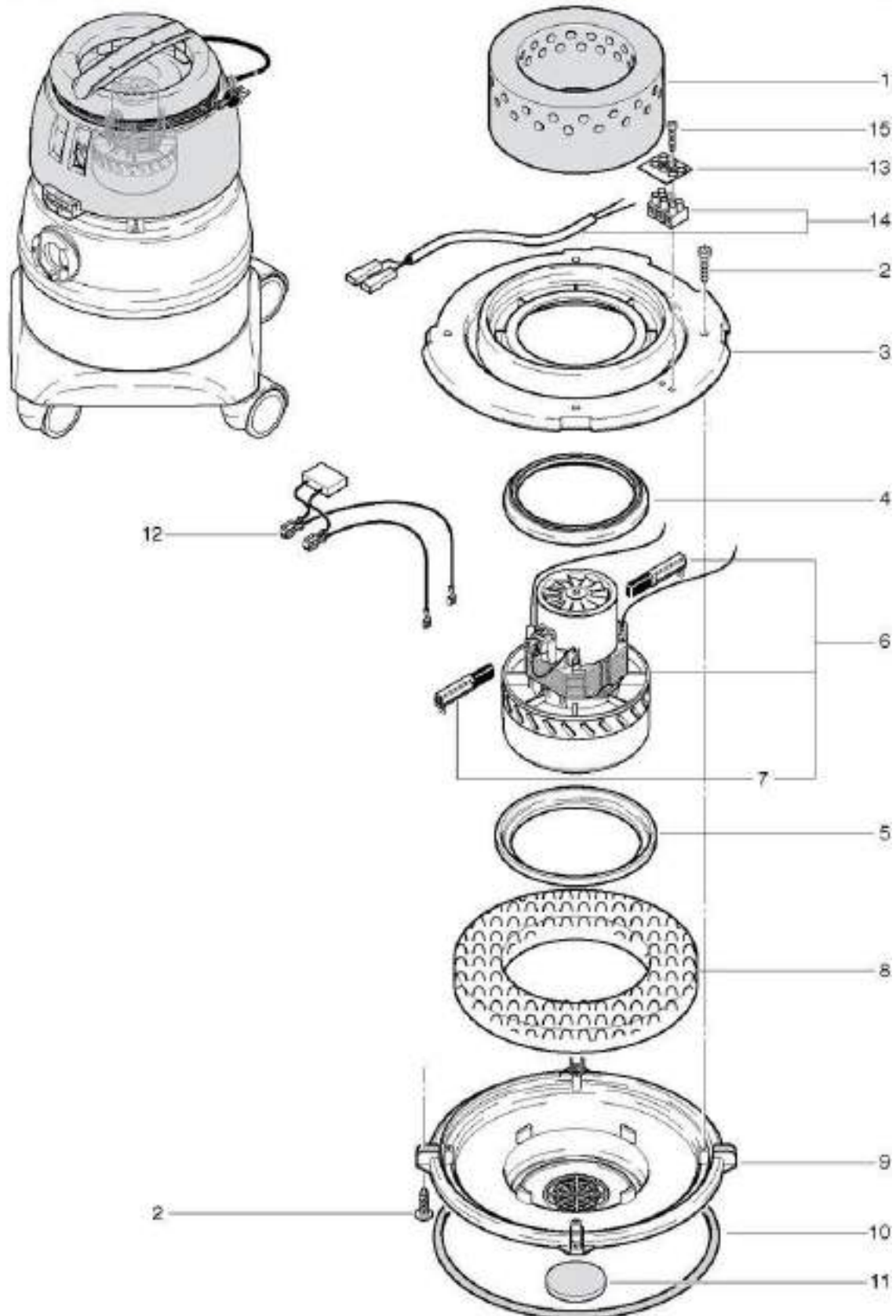

# SW 21 Combi

## Wiring diagram

Stand: 30.03.2017 21:22

SW-21

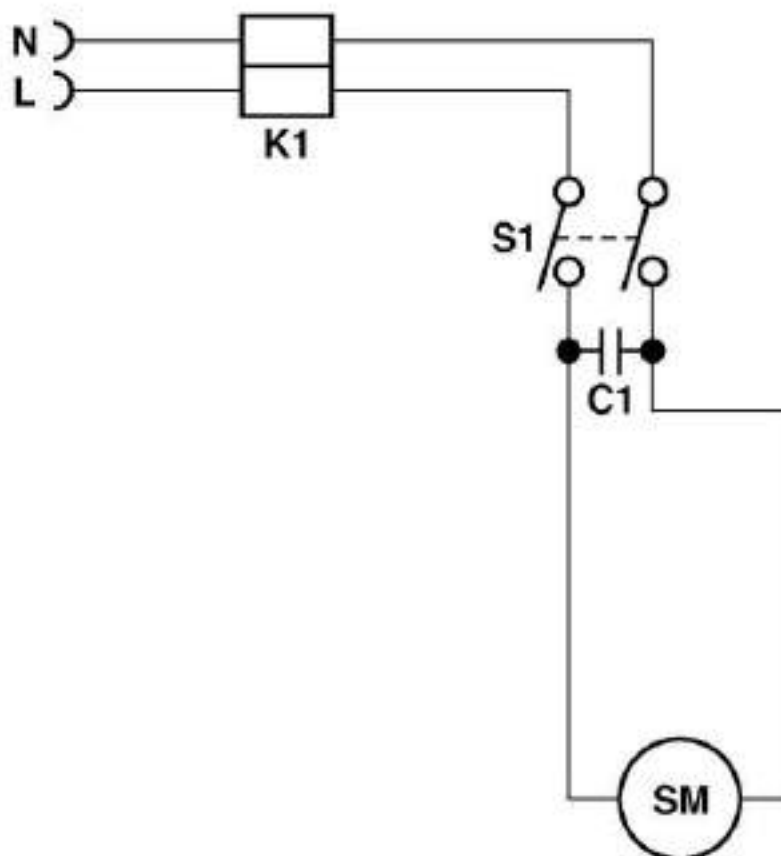

- K1 = Reihenklemme / Serre-fil / Cable clamp
- S1 = Wippenschalter / Interrupteur / Tumbler switch
- C1 = Kondensator / Condensateur / Capacitor 0.15 F
- SM = Saugmotor / Moteur d'aspiration / Vacuum motor